

VOLVO PENTA

Volvo Penta of the Americas
1300 Volvo Penta Drive
Chesapeake, Virginia 23320-9810

Service Bulletin

Group	Number	Version
23-1	22	02

Campaign: Demon™ Carburetor, Throttle Plate Screws 3.0GLP-J, 4.3GL-J, 4.3GL-JF

Distribution: M

Date: 02-2010

Binder: C

IMPORTANT! this revised bulletin contains a change in the procedure for checking the carburetors. See page 4.

Product Safety Recall - U.S. and Canada

Affected Models

3.0L and 4.3L Carbureted Gasoline Sterndrive Engines

Model	Spec. Number	Serial Number Ranges	
		10 digit	7 digit
3.0GLP-J	3869388	4012250992 - 4012258677	A104193 - A112954
4.3GL-J	3869391	4012250707 - 4012258760	A103867 - A114420
4.3GL-JF	3869392	4012252403 - 4012258107	n/a

Demon™ carburetors were also sold through Parts for use on earlier engine models. Dealers who purchased these carburetors will be contacted by Volvo Penta with recall details.

Campaign Information

Volvo Penta recently discovered that the engine models above, within the serial number ranges listed, have carburetors which may have improperly fastened throttle plate retaining screws. If these screws back out, the throttle may stick in the open position when the engine is operated, resulting in loss of throttle control by the operator. This bulletin provides instructions on how to properly inspect the throttle plate retaining screws, return any defective carburetors to Volvo Penta for repair, and then how to mark the carburetor after the inspection or repair has been completed.



WARNING! This service must be performed prior to the engine being operated.

All registered owners of affected engines are being notified by Volvo Penta of the need to have the carburetor throttle plate screws inspected by a Volvo Penta dealer prior to engine operation. When contacted by owners, dealers are required to perform this service at no cost to the customer and to file a warranty claim as indicated below for reimbursement directly by Volvo Penta.



WARNING! Federal law also requires dealers to repair defective carburetors on unsold units prior to retail sale.



WARNING! Boats that cannot be repaired at this time (e.g. in storage) should be clearly identified and tagged, indicating that this service bulletin must be performed before the boat is sold and/or the engine is operated.

Inspect Carburetor

Tools and Supplies

Read and understand the entire service bulletin before proceeding.

To minimize the time required for the inspection and/or the possible removal of the carburetor, gather the following tools and supplies before proceeding:

tags, blank	open-end wrench, 3/4"
marker pen	combination wrench, 1/2"
paint pen, yellow	fuel nut wrench, 16mm
flashlight	fuel nut wrench, 1/2"
ratchet	diagonal cutters
torque wrench	needlenose pliers
extensions	gasket scraper
3/4" socket	duct tape
1/2" socket	absorbent materials

Campaign Mark

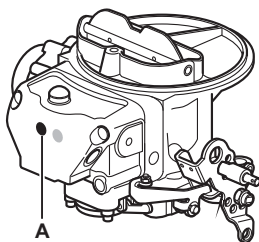

Before performing any inspection or repairs, check the carburetor for the campaign mark. Carburetors that have been inspected or repaired will have a YELLOW paint dot (A) on the front of the fuel bowl.

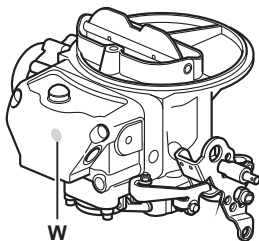

Also, **some** of these carburetors may have been inspected as part of an earlier campaign. 3.0GL and 4.3GL models within serial number range 4012250992 – 4012255637 should have a white mark (W). If not, see Service Bulletin 23-1-21 for details of the earlier campaign.

Carburetors with the white mark must still be inspected for this campaign. DO NOT confuse a white mark with the yellow mark for this campaign.

Before starting inspection



WARNING! To prevent accidental starts and other personnel injury;

Prevent the engine(s) from starting; disable all electrical power to the boat.

Tag the helm(s) to alert others that you are working on the engine(s).

Inspection

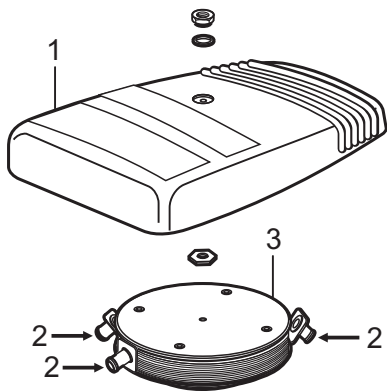

Remove the engine cover (1), if present.

Disconnect any hoses attached to the flame arrester (2).

Remove flame arrester (3) to gain access to the carburetor.

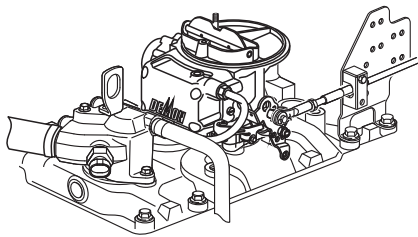

Manually open the choke plate (4)

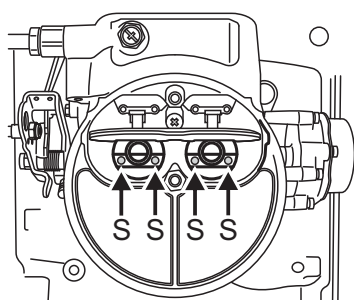
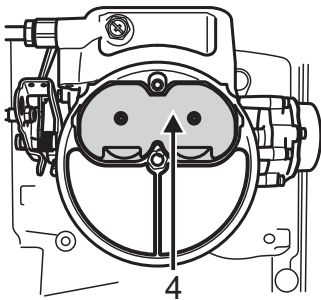

Looking down the main bore of the carburetor, check the ends of the four screws (S) used to secure the throttle plates to the throttle linkage rod.

IMPORTANT! this section contains a change in the procedure for checking the carburetors.

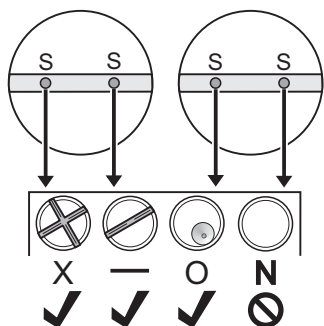

The end of each screw (S) should be staked (X, —) or dimpled (O). The staking or dimpling prevents the screw from backing out. Screws that are not (N) staked or dimpled may back out, and must be repaired (details below).

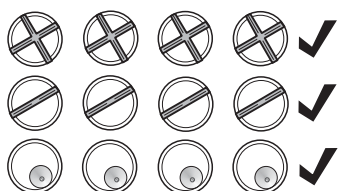

All four screws must be staked (X,—) or dimpled (O). If all four are staked or dimpled the carburetor passes inspection and should be returned to service. See “If the Carburetor Passes the Inspection” below.

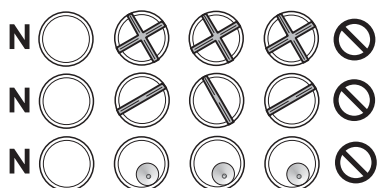

If the stake or dimple mark is missing (N) on the end of **any** of the four screws, the carburetor fails the inspection and must be removed and repaired, see “If the Carburetor Fails the Inspection” below.



If the end of any screw is marked, but it looks like the staking tool did not completely hit the screw, the carburetor fails the inspection and must be removed and repaired, see “If the Carburetor Fails the Inspection” below.

If the Carburetor Passes the Inspection

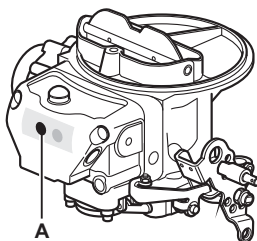

Place a yellow paint dot **A** to mark that inspection has been completed. The dot should be placed as indicated in the picture, within the shaded area.

Install the flame arrestor and nut.
Torque flame arrestor nut: 30-40 in.lb. (3.5-4.5 N•m)
Reconnect all hoses
Install the engine cover, washer and nut.
Torque engine cover nut: 30-40 in.lb. (3.5-4.5 N•m)

Remove tag(s) from helm station(s).
If needed, reconnect boat's electrical power.

Warranty Claim Information:

Note: It is important that a warranty claim is filed for every carburetor that is inspected.

File a warranty claim for the inspection, as follows:

Warranty type: 54
Function group: 2311
Failed part: 21211937
Reason code: 09
Campaign no.: 4877-1735

Flat Rate Labor Codes

23100 0.5 hour carburetor inspection

If the Carburetor Fails the Inspection

The carburetor must be removed from the engine and then returned to Volvo Penta. Follow the instructions below.

Do not attempt to repair the carburetor. Special tools are required for the repair. Repairs done incorrectly will damage the carburetor.

Order Return Shipping Kit

As soon as you know you have a failed carburetor, order kit 21503951 (one per carb.) from Volvo Penta Parts. The kit contains packaging and labels that are designed for returning the carburetor.

Tag Carburetor and Boat

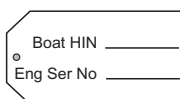

It is important that the carburetor removed from an engine is re-installed on that engine. Tag the carburetor with the boat's hull identification number and the serial number of the engine.

Tag all helm stations to alert others that the engine is being repaired according to a recall and must not be disturbed until the repairs have been completed.

Before Starting Carburetor Removal

⚠ WARNING! To prevent explosions, fires, accidental starts and other personnel injury during removal of the carburetor;

Disable all electrical power to the boat.
Shut off fuel supply.
Work area must be well ventilated.
No smoking or other sources of flame or spark.

Be prepared to contain or clean-up any fuel spilled when removing the carburetor. Dispose of any fuel and shop materials according to environmental regulations.



Remove Carburetor, 4.3L

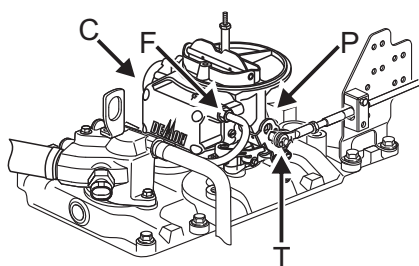

Disconnect throttle cable (T).

Remove clamp and then remove PCV hose (P).

Disconnect leads to electric choke (C).

Use an open-end wrench ($\frac{3}{4}$ ") and fuel nut wrench (16mm) to remove the fuel line (F). Seal or plug the end of the fuel line.

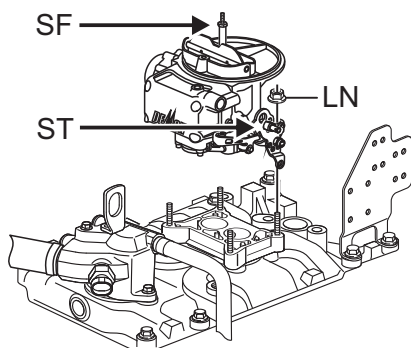

Use a wrench ($\frac{1}{2}$ ") to remove the flame arrestor stud (SF). Discard the stud.

Loosen and then remove the four lock nuts (LN) securing the carburetor. Remove the carburetor.

Do not remove the throttle pivot (ST) from the carburetor.

Remove Carburetor, 3.0L

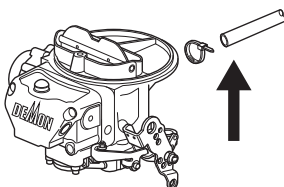

Remove tie strap and then the fuel over-flow hose.

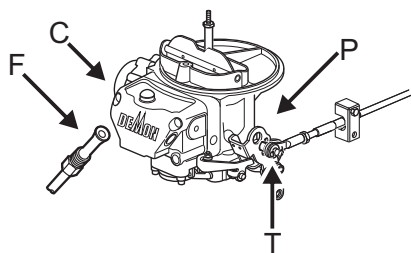

Disconnect throttle cable (T).

Remove clamp and then remove PCV hose (P).

Disconnect leads to electric choke (C).

Use a open-end wrench ($\frac{3}{4}$ ") and fuel nut wrench ($\frac{1}{2}$ ") to remove the fuel line (F). Seal or plug the end of the fuel line.

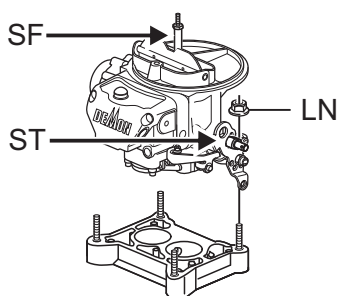

Use a wrench ($\frac{1}{2}$ ") to remove the flame arrestor stud (SF). Discard the stud.

Loosen and then remove the four lock nuts (LN) securing the carburetor. Remove the carburetor.

Do not remove the throttle pivot (ST) from the carburetor.

All Models

Clean the gasket mating surface of the carburetor spacer.

Seal the opening in the spacer with duct tape to prevent water or debris from entering the engine while the carburetor is removed.

Make sure all helm stations are tagged to alert others that the engine is being repaired according to a recall and must not be disturbed until the repairs have been completed.

Drain all fuel from carburetor!

Loosen lower fuel bowl screws to drain the fuel bowl. After fuel has drained re-torque screws: 30 in.lbs (3.5 N•m). Pump the accelerator pump several times, until all fuel is cleared.

Turn the carb upside down to drain.

Be prepared to contain or clean-up any fuel spilled when draining the carburetor. Dispose of any fuel and shop materials according to environmental regulations.

Return Carburetor



DANGER! do not ship carburetors with any fuel inside. Carburetor must be shipped by GROUND carrier, not air.

Use the shipping tag included in the kit (21503951) to insure the returned carburetor is shipped correctly.

When the Return Shipping Kit arrives:

Tag

Fill out the warranty tag 7750070 and attach to the carburetor.

VOLVO PENTA	WARRANTY PARTS TAG
	DEALER NAME _____
	DEALER CODE NO. _____
	WARRANTY CLAIM NO. _____
	DEALER R.O. NO. _____
	CUSTOMER NAME _____
DATE OF REPAIR _____	

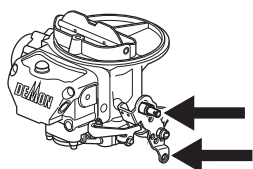

Pack

Use the bags in the kit (21503951) to double bag the carburetor. Use the boxes and inserts from the kit to pack the carburetor for return shipping. Follow the instructions in the kit. Make sure protruding parts are protected from bending or from puncturing the box.

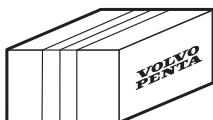

Close and seal the box.

Apply the pre-printed shipping label. The pre-printed shipping label insures that the carburetor is returned to the correct Volvo Penta location.

Follow the instructions on the pre-printed label for pick-up by the carrier and for shipping.

Carburetor Repair

Volvo Penta will make the necessary repairs and return the carburetor to the dealer as quickly as possible. The same carburetor will be returned. It is important that the carburetor removed from an engine is reinstalled on that engine.

When returned the carburetor will include:

gasket, flame arrestor stud, clamp (PCV hose), cotter pin (throttle), tie strap (over-flow hose, 3.0L only) and installation instructions.

The carburetor will also be marked with the campaign mark.

Re-install Carburetor

See instructions with returned carburetor.

Warranty Claim Information:

As soon as the repairs are complete, file a warranty claim for the procedure.

Warranty type: 54
Function group: 2311
Failed part: 21211937
Reason code: 09
Campaign no.: 4877-1735

Flat Rate Labor Codes

23111 1.0 hour carburetor, remove and reinstall
19924 0.2 hour pack and ship failed part to warranty

Note: Only one claim will be accepted for each serial number. Claims should be made for either an inspection (carburetor passes inspection) or for a removal/reinstallation (carburetor failed inspection), but not both.